



Under Tile/Timber Heater Kit Installation Guide

Please watch the under tile/ timber heater installation video
at www.coldbuster.com.au/learning-centre/videos/

WARNING: Failure to read this guide prior to installing the
COLDBUSTER heater may result in installation problems
that could void the heater warranty.

Coldbuster Helpline: 1800 85 75 65

Contents

Page 1- Introduction

Page 1- Coldbuster Contact Details

Page 2 – Installation Dos and Don'ts

Page 2 - Product Information

Page 2 - Tools Required for Heater Installation

Page 3 - Electrical Preparation

Page 4 - Floor Preparation

Page 4 - Floor Sensor Preparation

Page 4 - Plan the Layout

Page 5 - Heater Installation

Page 6 - Monitor Installation

Page 6 - Laying the Floor Covering

Page 7 - Multiple Heater Installations

Page 7 -Thermostat & Floor Sensor Connection

Page 8 - Warranty

Page 9 - Safety & Operating Instructions

Page 10 – Damage and Repair

Page 11 – Heater Position/Layout Sketch

Introduction

To ensure a simple and hassle-free installation, read this guide before commencing with installation.

Coldbuster does not accept responsibility for any loss or consequential damage suffered because of installations that in any way contravene the instructions detailed in this guide.

If you require further assistance, please contact Coldbuster during office hours (EST).

Contact Coldbuster

Unit 2/36 Campbell Avenue Cromer NSW 2099

1800 85 75 65

info@coldbuster.com.au

www.coldbuster.com.au

Installation Dos and Don'ts

Dos

- Ensure all heaters are installed as per these instructions
- Ensure the floor surface is smooth, clean and dry before installing heaters
- Plan the installation, especially when more than one heater is being installed
- Maintain a minimum 30mm spacing between elements
- Install the floor covering as soon as possible after heaters are installed
- Protect the heater with cardboard or hardboard if the floor covering installation is delayed
- Test heaters before installing the floor covering
- Ensure adhesives and grouts are suitable for use with floor heating
- Ensure the heater is connected to an RCD (safety switch) protected circuit
- Retain your invoice as proof of purchase for warranty purposes
- Complete the last page of this booklet for future reference

Do Nots

- **Do not ever cut heating element**
- Do not allow heating elements to touch or cross one another
- Do not allow harmful traffic (e.g. spiked boots, ladders, wheelbarrows) over the heater before installing floor covering
- Do not place sharp or heavy objects on uncovered heaters
- Do not install heaters under any surface not suitable for floor heating
- Do not install heating in shower recesses to prevent damage to heater due to fixing shower screens
- Do not commence installing the final floor cover before testing heaters
- Do not run the heater until the tile adhesive and grout has fully cured

Product Information

The Coldbuster Under Tile/Timber Heater Kit contains the following items:

- heater mounted on self-adhesive fibreglass mesh
- installation alarm monitor
- installation guide

The heating element is made up of 4 parts:

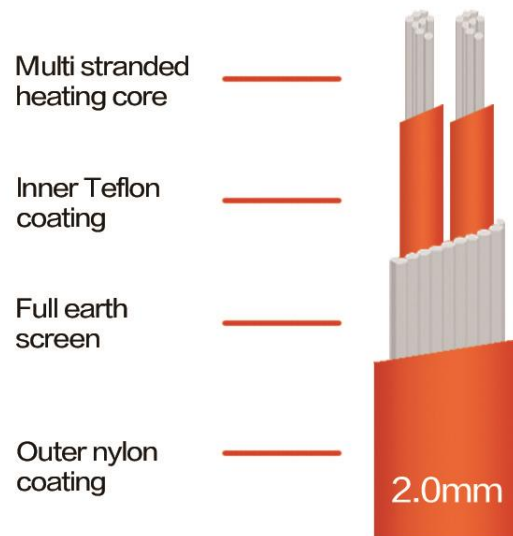

Tools Required for Heater Installation

The following tools are required:

- tape measure
- pencil or crayon
- cloth tape
- glue gun (optional)
- chisel & hammer or angle grinder
- bonding liquid (such as Bondcrete) mixed in 1:4 ratio with water and applied to the floor with a paint roller
- Optional to be used where heaters need to be covered for protection:
 - tile adhesive (20kg per 5sqm), large bucket and mixing paddle.
 - steel float or blunt edged trowel to apply tile adhesive

Electrical Preparation

The Coldbuster heater element has been classified as an electrical appliance. You must engage a licensed electrician for the heater installation if this is required by your state codes.

However, all electrical connections including the connection of the thermostat must be undertaken by a licensed electrician in accordance with current electrical codes of practice, AS/NZS3000:2007 and state codes.

Hardwire Connection

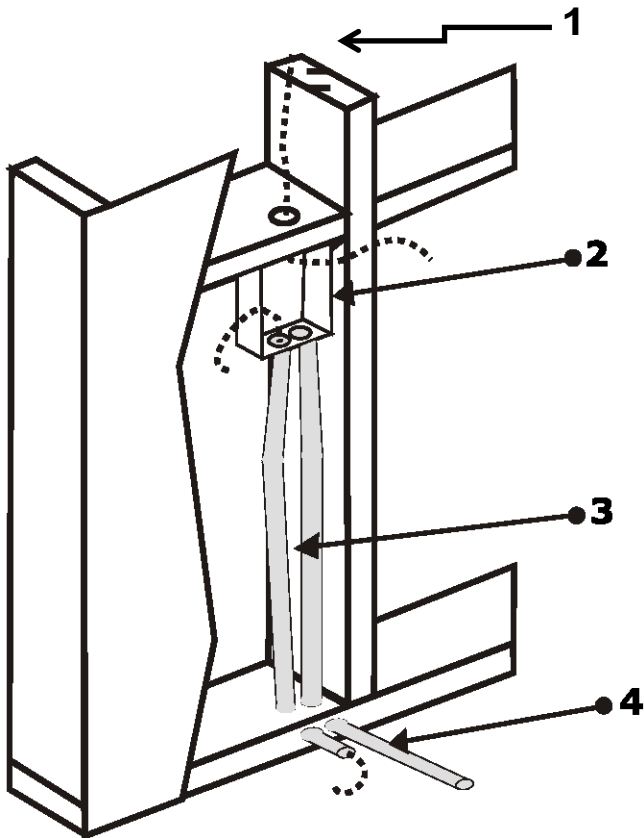

1. Power supply must be RCD protected
2. Standard flush box or C-bracket mounted horizontally or vertically, height between 1000mm -1500mm above the floor
3. 20mm conduit for the heater leads - maximum 2 heaters per conduit
4. 20mm conduit for floor sensor extended into the room (optional: the thermostat also has a built-in sensor and can be set up for air sensor)

RCD

The heater element must be connected to a circuit with RCD protection. Please consult with your electrician to ensure any existing cabling and RCD's already installed are working and capable of handling the additional load.

Plug-In Connection

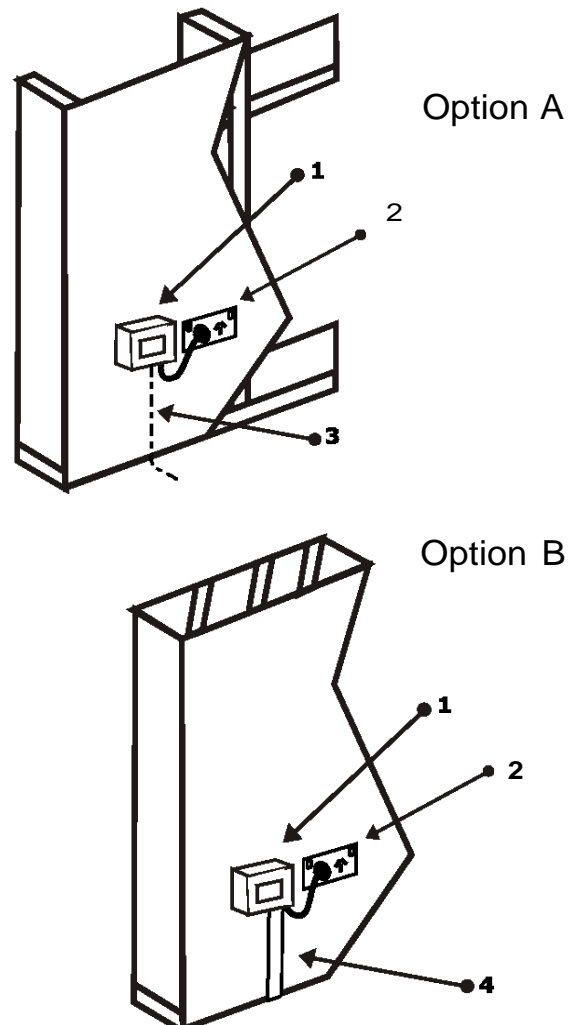

1. Thermostat mounted between 300-600mm from the floor
2. Power point must be RCD protected
3. **Option A** - for cavity walls fit heater lead and floor temperature sensor inside the cavity
4. **Option B** - for brick walls fit heater lead and floor temperature sensor inside PVC trunking and notch out the thermostat baseplate for cable access

Floor Preparation

This guide intends to serve only as an outline for the most common floor preparation required. Please contact us for any additional advice.

Concrete Floor Preparation

- The concrete must be completely cured (this can take up to 8 weeks)
- The floor surface must be smooth, unpainted and free of dust, oil, grease, tar and glue residues
- Clean and sweep or vacuum floor surface
- If heater(s) do not stick due to a dusty floor surface: 1. apply a coat of bonding liquid mixed 1:4 with water using a paint roller (avoid ponding), 2. allow bonding liquid to dry completely before installing heater(s)

Timber Subfloor preparation

- The floor should be rigid and free from movement
- Install a fibre cement underlay or insulation board over the timber structural floor before tiling
- The floor surface must be smooth, unpainted and free of dust, oil, grease, tar and glue residues floor
- Clean and sweep or vacuum floor surface
- If heater(s) do not stick due to a dusty floor surface: 1. apply a coat of bonding liquid mixed 1:4 with water using a paint roller (avoid ponding), 2. allow bonding liquid to dry completely before installing heater(s)

Floor Sensor preparation

Install the supplied floor probe sensor as shown in the electrical connection drawing, particularly if another form of heating such as air conditioning or a fireplace will also be used in the area.

Plan the layout

Step 1

Plan the position and shape of the heater(s) in the area(s) to be heated.

It is important to choose the correct heater(s) for the size of area. Installing a heater too small for the area will not produce enough heat to warm the area sufficiently. If the heater is too big for the area it simply won't fit and cannot be cut. If you are unsure about which heater size, refer to the kit packaging or the Coldbuster website before choosing your heater size.

The heaters are manufactured in strip form, 500mm wide. The strips may also be taken apart by cutting the mesh and tape and sticking the mesh strips down in various positions. **Care must be taken never to cut or cross the heating element.**

Ensure there is a 30mm gap between strips to maintain consistent space between the elements. Also ensure a distance no less than 200mm from any wall or permanent fixture is maintained

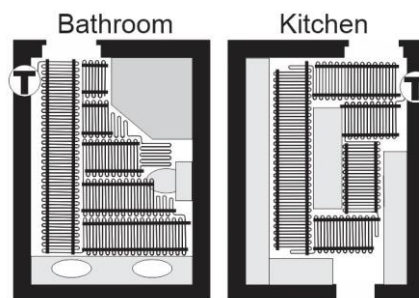

Step 2

The heater start points will be on the floor below the thermostat position. Chip away some of the sub floor with a chisel to form a cavity of about 10 mm deep to allow the connection joint (junction between element & cold tail) to be recessed into the floor. The size of the cavity will depend on the number of heaters to be connected to the thermostat. Hot glue gun or tape the connector blocks into the recess.

Heater Installation

Step 1

The general process is to roll out the heater & cut the mesh and tape where necessary according to your plan.

Take care not to cut the element.

Step 2

Place the heater with the sticky side of the mesh facing down. Ensure that the element is straight and under slight tension.

Heating elements must never touch or cross.

Step 3

Press the mesh down so that the mesh sticks to the floor and keeps the element in position. If part of the mesh lifts, it can be stuck down with duct tape or hot melt glue. Where necessary, separate the element into a single line to get to another point.

Step 4

Connect the cold tail to the draw wire and pull it up the wall cavity or through the pre-installed conduits to the thermostat position.

Connect the monitor to the cold lead and turn on.

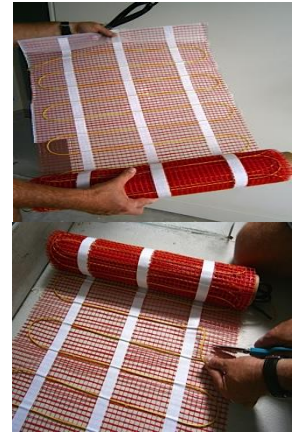

Step 5 (This step is optional)

For additional protection, we recommend applying a thin layer of flexible tile adhesive over the heater and mesh before tiling commences. This will also protect the element from accidental damage caused by removing the floor covering in the future.

Spread the tile adhesive evenly over the mesh with a steel float with rounded corners. Ensure the element stays in position and the adhesive penetrates through the mesh with complete coverage. Where a protective layer of tile adhesive has been applied, allow the adhesive to set.

Monitor Installation

Step 1

- a) Open the battery cover and check the battery is connected. Replace the battery cover and switch the unit to 'ON'.
- b) The alarm should sound and the red light should be on when there are no connections to a heater. If these things do not occur, inspect the battery connection or replace the battery. During normal use, the white light indicates that the monitor is continually checking the heater(s) for damage. Should the white light go out, replace the battery before continuing work.
- c) Make sure the heaters to be monitored are not connected to a power source. Connect the leads to the monitor prior to commencing any work to ensure faults are detected.



Step 2

- a) Strip the insulation around the tips of the cold tail and earth wire. Insert the blue wire into the black alligator clip, the brown wire into the red clip and the green earth wire into the green clip. Pull the rubber boots over the metal clips.
- b) Set the switch to the "ON" position. A white light indicates the monitor is operating.
- c) Hang or place the monitor where it can be seen and heard during the heater installation.
- d) A red light and alarm indicates that:
 - a lead wire has come loose from the terminals; or
 - either the red or black alligator clip is touching the green alligator clip; or
 - damage has occurred to the heater.
- e) In any such event, stop work straight away and locate the damaged spot. In event of damage, call Coldbuster 1800 85 75 65 for assistance.

Important: Leave the monitor connected to the heater until the tiling & grouting has been completed and your electrician has connected the thermostat.

Laying the Floor Covering

- Additional care should always be taken when working over floor heaters. It is recommended that a piece of cardboard or carpet is used to temporarily cover the heaters to avoid accidental damage to the heaters while laying floor covering in other areas.
- If the monitor sounds an alarm: stop work immediately and check monitor connections (see above), the heater element resistance and the insulation resistance. Test yourself if you have a multimeter, otherwise contact Coldbuster or your electrician.
- A flexible cement-based tile adhesive and grout suitable for floor heating must be used. Contact a floor-tiling supplier for advice if uncertain of the adhesive type.
- If tiles require lifting during tiling, slide a trowel under tile. Slide a second trowel between tile and first trowel and lever tile up. This avoids point pressure of lever trowel damaging heater element.
- Do not allow any heavy or sharp objects to fall, stand upon, run over or be dragged across heating elements. Place buckets of tile glue on a piece of hardy sheet to protect the element from the weight of the bucket. Do not use an angle grinder to create expansion joints.
- Grout the tiles as soon as possible according to the adhesive manufacturer's guidelines.
- Do not switch heaters on until tile adhesive has cured in accordance with adhesive & grout manufacturer's guidelines (usually about 7 days).
- Disconnect monitor from heater before connecting heater to thermostat & mains.

Important: The monitor will detect damage to the element needing to be repaired immediately (cuts to the element). Bruising damage will only manifest at 240V. An insulation (Megger) test by an electrician is recommended.

Multiple heater installations

If you are installing multiple heaters into an area and using just one thermostat, all heater wires will need to start at the same point.

Remember to maintain spacing of no less than 30mm between heater wires. Do not allow heater wires to cross. Do not allow the blocks to touch in the cavity.

Each heater must be tested and fitted with its own monitor. Monitors can be reused for future installations

MULTIPLE heaters must be connected in PARALLEL

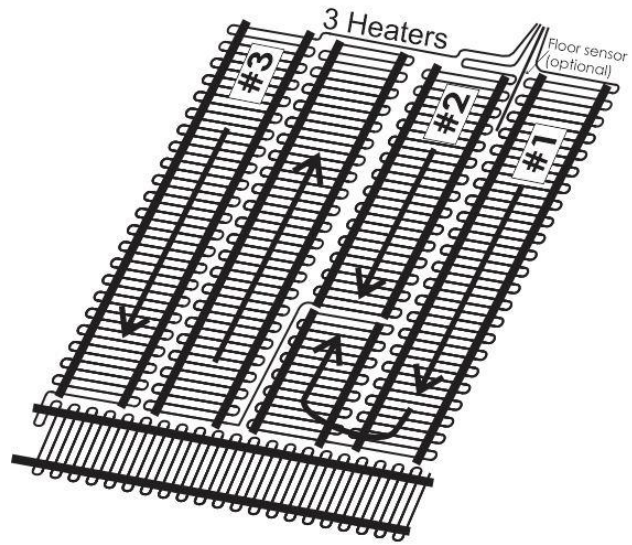

Thermostat & Floor Sensor Connection

Important: Check your thermostat instructions for wiring details.

Remember:

- These are double insulated devices - there is no earth connection to the thermostat.
- The earths of the heater(s) connect directly to the earth of the supply in a screw connector.
- The floor sensor is essential where the thermostat is mounted inside a cupboard or vanity or outside the area being heated. Otherwise, the use of the floor sensor is optional, but recommended.

Warranty

Coldbuster guarantees its products subject to the following conditions:

1. The product is free of defects at the time it was supplied. The product will be deemed to be defect-free if no defect has been detected and reported to Coldbuster:
 - a) within 10 years (120 months) from date of purchase (for heaters); or
 - b) 3 years (36 months) from date of purchase (for thermostats).
2. The following are conditions of this guarantee:
 - a) a competent person installed the product;
 - b) the installation was carried out according to the directions as supplied by Coldbuster;
 - c) the installation was carried out in accordance with all applicable electrical regulations; and
 - d) the heater has been connected to a RCD protected supply circuit.
3. Damage during installation by others is not covered by warranty.
4. Damage or repair to a product by another party voids this guarantee. Repairs done by Coldbuster to rectify such damage cannot be guaranteed and the client will be charged regardless of the result.
5. Claims under this guarantee must be lodged with Coldbuster, in writing, within the period prescribed. Full particulars must be given and a copy of the invoice as proof of purchase must be enclosed.
6. In settlement of its obligations under the guarantee set out above, Coldbuster shall, at its option, either:
 - a) repair or replace the defective part without charge; or
 - b) pay the purchaser a sum equal to the price paid for the defective part at the time of purchase.
7. Coldbuster's liability to the purchaser is limited to amounts referred to herein. The purchaser agrees that Coldbuster shall not be liable for any other or additional damages suffered by the purchaser caused by any defects in the product, the installation itself or any constituent part of it. Coldbuster shall not be liable to compensate the purchaser for any floor coverings or any other item damaged or destroyed as a result of any such defects.
8. This guarantee is subject to the purchaser adhering to all safety and operating instructions.
9. This warranty is non-transferable.

Safety & Operating Instructions

Safety Guidelines

Every heater is thoroughly tested before shipping and is guaranteed to be in good working order on dispatch. This is an electrical heating system and must be used strictly in accordance with the manufacturer's instructions.

- DO NOT drill holes or drive sharp objects i.e. nails or screws into your floor without knowing with absolute certainty that you will not touch the heating elements.
- Replacing damaged tiles will, if not done properly, cause damage to the heaters. Please contact the Coldbuster helpline before undertaking such work.
- Heaters **must** be connected through an RCD (safety switch) circuit breaker. In case of damage or the unlikely event of heater failure, the RCD switch will trip and cut off power to the heating. In this case, turn off the thermostat and contact Coldbuster. Do not attempt to repair the heater.
- Inform any person who takes occupation of the property about the position of the heaters.
- Pass these safety and operating instructions on to new owners or tenants.

Economy Tips

Most people find 20°C a comfortable room temperature. The lower the temperature you set on the thermostat, the less electricity the heating uses. We advise you to experiment to find the most comfortable setting. 18-20°C is often found to be warm enough, depending on activities in the area, because floor heating is efficient in creating comfort.

The temperature of the floor depends on the heat required to maintain the room temperature you select. If it is very cold outside, the floor will have to be warmer to maintain the same room temperature than when it is moderately cold outside.

For regularly occupied areas, you may wish to consider leaving the thermostat on a setting between 12-15°C rather than switching it off when not occupied, so the floor and area never become too cold. This may be cost effective as the heater may not have to stay on very long to maintain the required temperature and will require less power when getting to the selected temperature when occupied.

A cold area will not heat up any faster by setting the thermostat to its maximum setting. Simply set the thermostat to your desired temperature and the heater will draw maximum power until the selected temperature is reached.

Heat is lost through windows, doors, ceiling and walls. Having insulation in the ceiling and walls and keeping doors, windows and curtains closed can reduce heat losses. Reducing heat losses will make your heating system run more efficiently and economically. Other common sources of heat loss: open chimneys, fireplaces, stairwells and A/C ceiling grilles.

Damage and Repair

The Coldbuster under tile/timber heater is free of defects at the time it was supplied. The risk of damage passes on to the person doing the installation and this risk is not covered by the Coldbuster warranty. Any repair to the heater voids the warranty.

If the monitor sounds an alarm and the LED lights up red during installation, stop work immediately and remove the tile and adhesive where the damage has occurred.

If the damage is not clearly visible, use an insulation tester set at 1000V connected to the element and the earth screen. This should create a spark where the damage has occurred.

The repair can be done in the following manner:

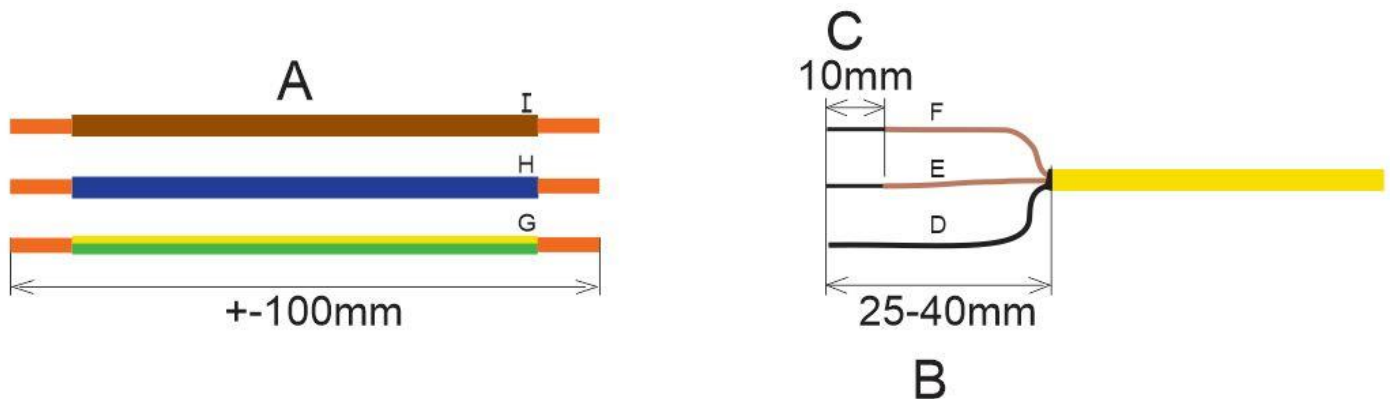

1. Strip back the outer insulation of the cold tail & cut off about 100mm of (non-resistive wire) brown, blue & earth wire (A). On each of these lengths, strip off the insulation to expose about 10mm of copper at each end.
2. Using a blade, strip about 25-40mm of the outer Nylon coating off the heating element (B).
3. Separate the earth screen (D) from the insulated 2 inner cores (E&F) and twist the strands of the earth screen (D) together.
4. Strip about 10mm of the Polymer coating of the 2 elements (E&F) by heating it with a flame until it melts, then pull it off.
5. One at a time (2 elements & earth wire), slip a crimp tube over the end. Then insert respectively the non-resistive wire into the crimp tube. i.e. I&F, E&H and D&G. The green/yellow earth wire (G) is the only wire that must be connected to the outer earth screen braided wires (D) that were twisted together earlier. The 10mm ends of the non-resistive wire & the element end should now be side by side with the crimp tube over it. The crimp tube can now be crimp together with the correct crimping tool. If crimps are not available, the connection can be soldered.
6. Before doing the other ends, slip a 2 x 25mm heat shrink tube over the crimp of each wire (H&I) of the heating element and shrink with heat. The earth wire (G) does not need a heat shrink tube over it.
7. Recess the repair joins and cover with hot melt glue or non-conductive silicone.



Electrical connections and repairs must be undertaken by a licensed electrician

Heater position/layout sketch

KEEP FOR FUTURE REFERENCE

Sketch out the position of your heater(s), the walls and other fixed fittings. Keep this manual and diagram for your reference and pass on to future occupants. Record the details below, as this can be used to validate the heater and thermostat warranties.

Date of Purchase..... Heater model number(s).....

Invoice number..... Installed by.....

Date Installed:	Element Resistance Test			"Megger" Insulation test @ 500V	Sensor Resistance Test
/ /	A - N	A - E	N - E		
Date Connected:	Ohm	Ohm	Ohm	M Ohm	K Ohm
/ /	Ω	Ω	Ω	MΩ	KΩ

Record heating layout and test readings on this page to comply with the 10-year warranty.